

FUNCTIONAL VERIFICATION OF WORKING SECTION FOR STRIP-TILL CULTIVATION

Summary

The paper presents research results of working section for Strip-Till cultivation, developed in a project PBS1/B8/4/2012 conducted under the Applied Research Programme. Working section is composed of several working elements which prepare the row of soil for sowing. The purpose of the study was to verify the functional aspect of the working section in the field.

Key words: research model, strip-till cultivation, working section, field tests

WERYFIKACJA FUNKCJONALNA SEKCJI ROBOCZEJ DO UPRAWY PASOWEJ

Streszczenie

Przedstawiono wyniki badań sekcji roboczej do uprawy pasowej opracowanej w projekcie PBS1/B8/4/2012 realizowanym w ramach Programu Badań Stosowanych. Sekcja składa się z kilku elementów roboczych, które przygotowują pas gleby pod siew, a celem badań była jej weryfikacja funkcjonalna w warunkach polowych.

Słowa kluczowe: model badawczy, uprawa pasowa, sekcja robocza, badania polowe

1. Introduction

Strip-till cultivation has the advantages of intensive soil tillage and direct sowing [2], and relies on loosening and seasoning only narrow strips of land, which at the same time or in a separate procedure are planted the seeds in rows. It is used for plants grown in rows with wide spacing (eg. corn, beets) and, unlike the classical cultivation is less energy-intensive, as it covers 30-50% of the field area. Other advantages of strip-till cultivation, inter alia, are the protection of soil from erosion by mulch stored in the inter-row, conservation of soil water, the continuity of biological life in the soil profile, sowing on area with a small amount of crop residues and good conditions for plant growth due to deep soil loosening exactly in rows.

Equipment for strip-till cultivation are composed mostly from the section containing several work items [3], which, depending on the soil conditions allow for its proper cultivation. The basic elements of such a section is a tine deep leavening the soil and the shaft thickening it again, but are also used additional elements, whose mission is to improve the quality of crops, in particularly difficult conditions.

2. The purpose of research

The aim was to verify the functional aspect of the working section in the field for strip-till cultivation including evaluation of the impact of individual working components on the final effect of the crop. Moreover working resistances of section was rated and resistance to overloads caused by stone impact in the tooth, which is the most deeply placed part of all working elements.

3. Research model

The study was conducted on a test model of the working section for strip-till cultivation (fig. 1). Complete working section is made up of a disc cutter, wheel and star shaped

cleaners mounted in a fixed frame handles and tine, discs and shaft mounted on the arm protected by seven-leaf-spring. The basic element of the working section is a tine (with a height of 750 mm), which loosens the soil deeply, while all other working elements improve the quality of crops, and by regulations, the correct setting may be required relative to the depth of the tine. The tine is equipped with extended forward coulter with a width of 60 mm and fixed next scoring unit with a width of 120 mm. The first operating elements of working section mounted on a common handle are: a disc cutter with 480 mm diameter and a wheels having a diameter of 400 mm and a width of 80 mm.

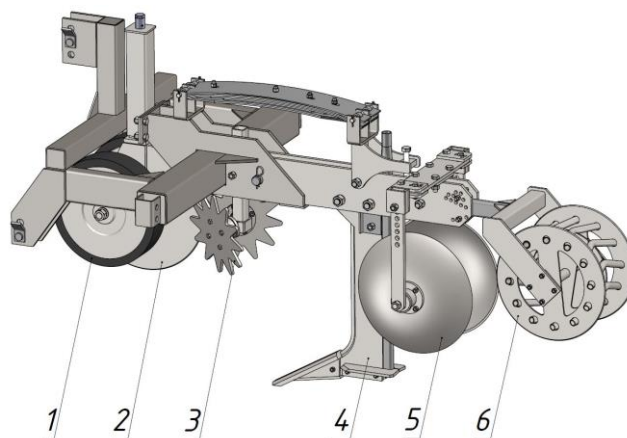

Source: Own work / Źródło: opracowanie własne

Fig. 1. Research model of working section for strip till:
1 – wheel, 2 – disc cutter, 3 – star shaped cleaner, 4 – tine,
5 – disc, 6 – shaft

Rys. 1. Model badawczy sekcji roboczej do uprawy pasowej:
1 – koło, 2 – krój tarczowy, 3 – gwiazda czyszcząca,
4 – ząb, 5 – talerz, 6 – wał

Disc cutter is mounted in a fork, the wheels on the sides of the fork, wherein the plurality of holes in fork allow to mount the wheel at different heights, thereby adjusting the disc cutter relative to the wheels.

The two stars cleaners are attached before the teeth, having a diameter of 320 mm and are arranged obliquely (30°) to the direction of work. Behind the tine are mounted two discs having a diameter of 460 mm, which can be set in accordance with the direction of work or obliquely (max 18°). The last working element of the section is the shaft. In the test model is used in option string-disc shaft with a diameter of 350 mm on the circumference of the strings, and 440 mm on the circumference of the discs and Crosskill shaft of diameter 440 mm. Width of string-disc shaft is 250 mm and the Crosskill ring is 80 mm.

4. Test results

During the study a research model was aggregated with the tractor Ursus 4512 (66 hp), and the operation speed was approx. 6 kmph. Field trials conducted on medium soils, on the stubble after rye (fig. 2) and shallow plowing stubble after rye and rape. In order to test the effect of individual working components on the final result of strip-till cultivation, they are used in various combinations into the working section.



Source: Own work / Źródło: opracowanie własne

Fig. 2. Model of working section for strip till during field tests

Rys. 2. Model sekcji roboczej do uprawy pasowej podczas badań polowych

The quality of strip-till cultivation

Disc cutter with wheels provides a very good cut of crop residues and the wheel also set the depth of cultivation. The study examined the effect of single disc cut and with wheels assistance. On concise soils with hard cover disc cutter provides cut most of the crop residue. In contrast, on soils with a low surface compaction the side wheels had beneficial effect, that pressing the long crop residues to the soil surface, allow complete cut them off, even at low (6 cm) recess of the disc cutter. Studies have shown that fragmentation of crop residues and soil in the surface layer has a beneficial effect on the action of the star shaped cleaners and the tine, eliminating their clogging by long remnants.

Star shape cleaners very well accumulate on the sides the crop residues which are cut by the disc. The benefit is not only from the removal of the remnants from the front of the tine core, but also clean the prepared seedbed lane across the width up to 30 cm (fig. 3) and placing the plant fragments in the inter-row. Studies have shown that the star shape cleaners turn very well at the small (approx. 2 cm) recess of tabs, and on field tests under various conditions there are no cases of blockage, even when large amounts of straw are split by disc cutter.



Source: Own work / Źródło: opracowanie własne

Fig. 3. Soil belts cultivated by section without (bottom) and with the star shaped cleaners (top)

Rys. 3. Pasy gleby uprawionej sekcją bez gwiazd (od dołu) i z gwiazdami (od góry)

The tine used in the test model well loosens the soil to a depth of 20-40 cm. Then the whole coulter is recessed and does not throw soil from the innermost layer to the surface, and after tine passing in the loosened soil is visible only narrow gap. Forward oriented coulter very easy enter into the soil and with the scoring unit mounted behind gently rises the soil causing their loosening. Soil loosening by the tine, thanks to earlier cutting the hard shell and crop residues by disc cutter freely accumulate on the surface and opens before the front of tine core, and the residues are not hang on it. The increase in thickness of the soil as a result of loosening is dependent on the depth of the cultivation and is 5-8 cm. Soil loosening zone extends from soil undercutting level, and depending on the soil depth is growing on the surface level up to 27-35 cm, and thus is close to the width of lane purified by the cleaning stars.

Discs are raking in lifted soil on the sides of the tine core and are cover up the trace of the tine and in result improve

the quality of the pressing loosened soil by the shaft. Finally, after passing the discs, with the small depth (up to 5 cm) and the rake angle (12°), after the tine pass, it forms the ridge of soil (fig. 4) which, when pressed by the shaft seals the hollow left in the soil by the core of the tine. In case of concomitant use of star shaped cleaners the discs do not reimpose crop residues on the loosened trace because their spacing is less than the width of lane purified by star cleaners.

The shaft seasoning the loosened soil crushing and compacting it. The study examined two types of shafts and stating that more useful is string-disc shaft that provides a higher density of soil and it's surface crushing in a row of 25 cm width. Crosskill ring crushes soil well, but because of the small width it pressed only the center of loosened row and leaves the groove. On the other hand string-disc shaft leaves a flat surface on cultivated row (fig. 4). Wedge bent strings are tightened soil with short harvest residues, and side screens prevent of soil spillage on the sides, but not limited string recess. The degree of shaft compaction depends on the soil loosened depth. For the same pressure of shaft more soil compaction occurs when the thickness of the loosened layer is smaller, and therefore with a smaller depth of loosened soil. On the basis of soil exposures in rows, no voids found within the working area of the coulters and the tine core after soil compression by the shaft. During the tests the measurements of conciseness of the soil carried out before and after the cultivation (table 1), showing a good compaction of the loosened soil by the shaft.

Table 1. The results of soil compaction measurements
Tab. 1. Wyniki pomiarów zwięzłości gleby

Depth of cultivation Measurement depth [cm]	Soil compaction [kPa]		
	before cultivation	after loosening by the tine	after pressing by the shaft
35/10	780	80	280
35/20	1230	85	320
35/30	3400	65	250
25/10	780	75	290
25/20	1230	80	360

Source: Own work / Źródło: opracowanie własne

Operating resistances

During the tests, measurements of working resistance in sections was made, which depend primarily on soil compaction and depth of the tine loosening. Other work elements, due to the small working depth, have only little effect on the section resistance. Measurements were performed on the stubble after rye, on soil compaction 1230 kPa at a depth of 20 cm, and 3400 kPa at a depth of 30 cm revealed that the pulling force required to overcome working resistance of the section is:

- 2400-3000 N at cultivation depth of 25 cm,
- 4100-4900 N at cultivation depth of 35 cm.



Trace of tine covered by discs

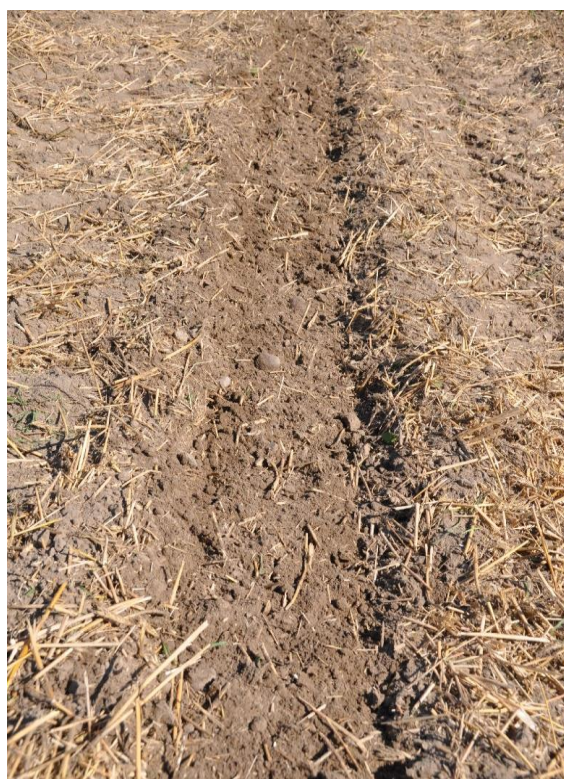

Soil belt after shaft pressing

Fig. 4. Belts of the soil before and after shaft pressing
Rys. 4. Pasy gleby przed i po dociśnięciu walem

Source: Own work / Źródło: opracowanie własne

A large increase in resistance with increasing tillage depth from 25 to 35 cm due to the high conciseness of the soil at the bottom of the arable layer, where arrears excessively concentrated "plow sole". During the study found numerous instances of excessive overloads from stones impacts. Especially dangerous are stones lying at great depth, firmly embedded in the concise soil. Once you hit the stone, leaf spring well cushion the impact overload, with a slight slope of the tine and then a quick return to full depth after passing the stone.

The deflection of the leaf spring does not completely put the tine above the surface of the field, and so when overload appears the depth of cultivation is reduced, rather than complete stop. During test the overload run was conducted, which showed that the pulling force at which the deflection of the leaf spring are shown is approx. 8000 N, and so is approx. 2-fold higher than the maximum working resistance measured during the study.

5. Conclusions

1. The tine loosening the soil to the required depth and shaft pressing loosened trace are the basic elements of the working section to perform strip till cultivation.
2. Disc cutter is useful for cutting hard cover of soil and crop residues that may cause clogging of the tine, wherein the side wheels pushing long residues to the soil improves the cutting.

3. Star shaped cleaners are useful for removing excess of crop residues from the cultivated row and stacking them in the inter-row.
4. Discs are useful for scraping uplifted soil on sides, which improves soil pressing by shaft and closes the gap after the core of the tine.
5. Width of pressing shaft should be approximate to the width of the soil row cleaned by stars shaped tool and loosened by tine.
6. Working resistance of the section is 2400-3000 N when the tine is placed on depth 25 cm and grown up to 70% at 10 cm trough more, when coulter cuts excessively compacted soil in the "sole plow".

5. References

- [1] Antosik G.: Fast, simple and effective cultivation. *ATR Express*, 03/2010, p. 5-6.
- [2] Przybył J., Mioduszevska N.: Strip Tillage, czyli uprawa pasowa. *Rolniczy Przegląd Techniczny* nr 1/2012, p. 32-35.
- [3] Szulc T., Talarczyk W., Kamprowski R., Bąkiewicz P.: Analysis of the technical possibilities of the new fertilizer dosage in the form of supergranule and placing it deep in the soil during the strip till. Report, PIMR, Poznań, 2013.
- [4] Talarczyk W., Szulc T., Łowiński L., Pikoś M., Kamprowski R., Bąkiewicz P.: Design, construction and testing research model of working section for dosing fertilizer in the form of supergranule and placing it deep in the soil. Report, PIMR, Poznań, 2013.