

MODELING OF THE PROCESS OF CUTTING WITH DRUM CUTTING UNIT

Summary

The mathematical model of the process of cutting of a layer of plant material with the use of the drum cutting unit is presented in the study. The drawn up model, following its positive experimental verification, may be used at the stage of designing new constructions of cutting drums used in self-propelled or stationary chaff cutters. The new model makes it possible to calculate the cutting operations made by individual drum's knives at the time of cutting of the material's layer and to determine its starting torque.

Key words: cutting drum, modeling of the cutting process, plant material

1. Introduction

The drum cutting unit constitutes the basic working unit in self-propelled or stationary chaff cutters [1-6]. The task of the drum cutting unit is to shred plant material into chaff. The cutting drum consists most often of a shaft to which shields with openings are fixed. Between the shields there are assembled cutter holders in the form of flat stripes with bracket for attachment. Cutting knives are attached to the holders. These knives, depending on a drum's construction, may be straight or bended along the screw line. Moreover, there are distinguished uniform or sectional knives. A cutting drum is borne in side plates of a chaff cutter, thanks to what it may make a rotary motion. The rotary motion of the drum results in dislocation of mounted knives. Knives dislocation vs. immovable shear plate (ledger plate) results in cutting of the layer of the plant material. Supply of material between the blade and shear plate takes place in the space of rotating pulling in- crushing rolls, where the plant material is subject to preliminary forming and pressing. The essence of construction of the drum cutting unit is presented in fig. 1.

The analysis of the up to now studies on the drum cutting units show, that they were conducted within a limited scope and consisted mostly in checking, whether a given construction meet the functionality requirement. It results from the fact, that looking for new solutions and improvement of the existing constructions have preceded learning on mechanical phenomenon occurring in the process of cutting of material's layer, and due to that – drawing up of theoretical bases of their designing.

Due to the above, the purpose of the study is drawing up of the mathematical model of plant material's cutting process with a drum cutting unit in the aspect of cutting operation by individual drum's knives.

2. Mathematical modeling

Based on observations of cutting of a plant material's pressed layer with the use of a drum cutting unit, a mathematical model of that process was suggested. The system of forces on the knife while cutting the layer of material is presented in fig. 2.

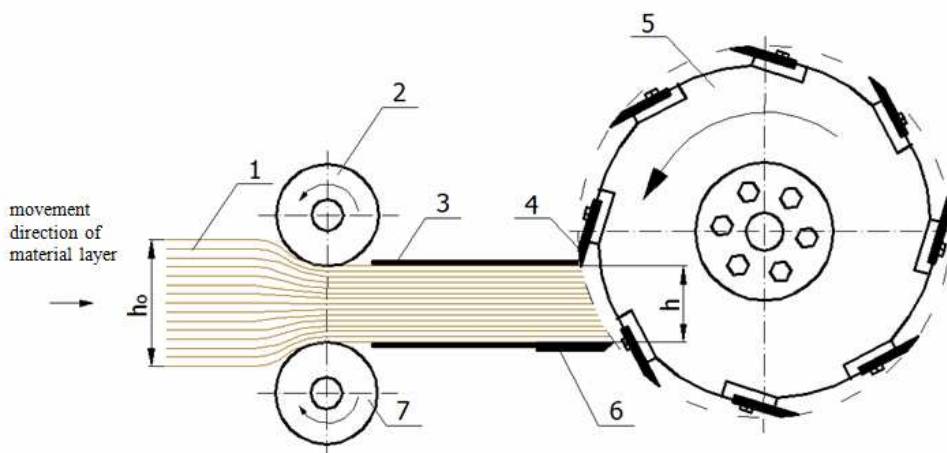

Fig. 1. Drum cutting unit: 1 – material's layer, 2 – upper pulling in-crushing roller, 3 – pressure plate, 4 – cutting knife, 5 – cutting drum, 6 – shear plate(ledger plate), 7 – lower pulling in-crushing roller, h_0 – height of the material's layer before compacting, h – height of the material's layer following compacting

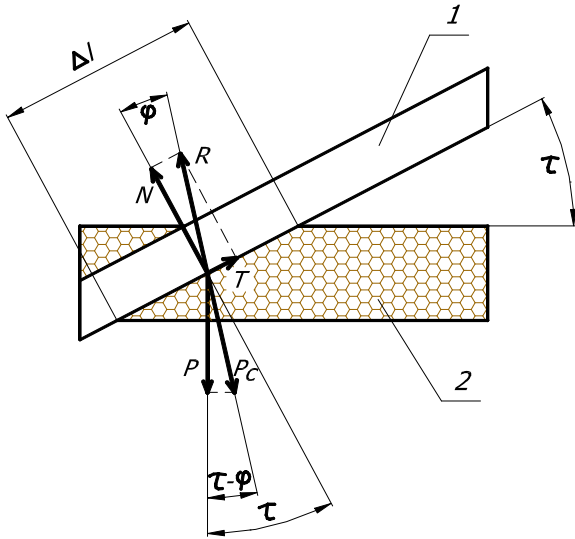

Fig. 2. System of forces occurring while cutting the layer of stalks by the cutting drum's knife: 1 – cutting drum's knife, 2 – layer of stalks

The task of the circumferential force P , presented in fig. 2, is to overcome the resultant cutting resistance P_c equal to the value of reaction R composed of: normal force N and friction force T , that came into being as a result of the layer's affecting the knife.

The value of the normal force N depends on the unit cutting resistance p_c and active length of the knife Δl :

$$N = p_c \Delta l. \quad (1)$$

Friction force T depends on the friction angle φ and is expressed by equation:

$$T = N \tan \varphi = p_c \Delta l \tan \varphi. \quad (2)$$

So, the resultant cutting friction P_c coming from normal force and friction force shall be expressed by equation:

$$P_c = \frac{p_c \Delta l}{\cos \varphi}. \quad (3)$$

The circumferential force P is the vertical component of cutting friction P_c and is expressed by equation:

$$P = P_c \cos(\tau - \varphi) = \frac{p_c \Delta l}{\cos \varphi} \cos(\tau - \varphi). \quad (4)$$

Following transformations of the equation (4) and considering that: $\tan \tau = \mu$, where μ is the coefficient of knife's friction against the cut layer of plant material, we shall get the circumferential force's formula P :

$$P = \frac{p_c \Delta l}{\cos \varphi} \cos \tau \cos \varphi (1 + \mu \tan \tau) = p_c \Delta l \cos \tau (1 + \mu \tan \tau). \quad (5)$$

Analyzing cutting of the rectangular layer of plant material, division of his process into 3 phases with the following assumptions, was done:

- each time, the layer of the material is cut only by one knife;
- the height of the layer of the cut material is equal to the distance passed by a given knife's point, getting through that layer.

I PHASE: Knife's penetration in the layer (active length of the knife Δl increases).

Pursuant to fig. 3a the difference between the length of arch drawn by any knife's point from the upper to the lower edge of the cut layer is approximately equal to the height of the layer h , what results from the fact, that for small angles

we assume $h \approx h \frac{\Psi}{\sin \Psi}$, as $\sin \Psi \approx \Psi$

Making use of trigonometrical relationship $\frac{x}{\Delta l} = \sin \tau$, we get:

$$\Delta l = \frac{x}{\sin \tau}. \quad (6)$$

For $x = h$ the formula (6) looks in the following:

$$\Delta l = \frac{h}{\sin \tau}.$$

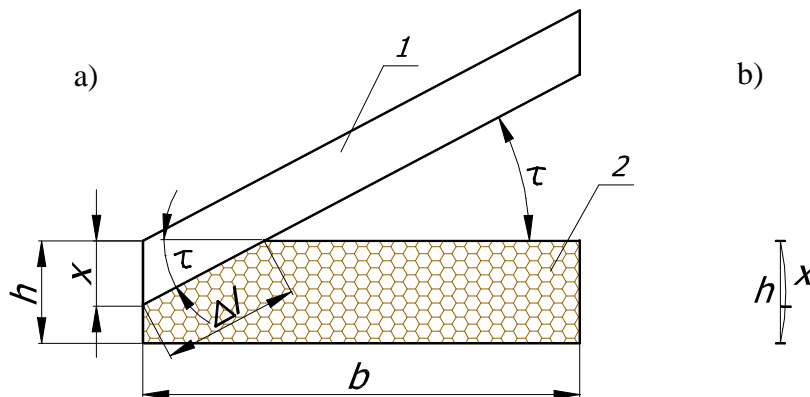

Fig. 3. Drilling of a knife into the layer (I phase): a) cross-section through the layer, b) comparison of the length of an arch x marked by a knife and the height of the layer h , 1 – knife of a cutting drum, 2 – layer of stalks

So, the cutting operation L_{nl} in the I phase of knife's motion may be presented with dependence:

$$L_{nl} = \frac{1}{r} \int_0^h M_c(x) dx, \quad (7)$$

where -

$M_c(x)$ – cutting moment depending on knife's location.

Taking into consideration that:

$$M_c = C \frac{x}{\sin \tau}. \quad (8)$$

The cutting work within the range $0 \leq x \leq h$ may be described with dependency:

$$L_{nl} = \frac{C}{r} \int_0^h \frac{x}{\sin \tau} dx = \frac{C}{r} \left[\frac{x^2}{2 \sin \tau} \right]_0^h = \frac{C}{r} \frac{h^2}{2 \sin \tau}, \quad (9)$$

where:

$C = p_c r \cos \tau (1 + \mu t g \tau)$ - the constant also occurring in the remaining dependencies.

II PHASE: Cutting of the layer (active length of the knife Δl remains constant)

Pursuant to fig. 4, cutting in the second phase takes place within the range $h \leq x \leq b t g \tau$.

Within the range $h \leq x \leq b t g \tau$, the value Δl is

constant and is described by dependence $\Delta l = \frac{h}{\sin \tau}$.

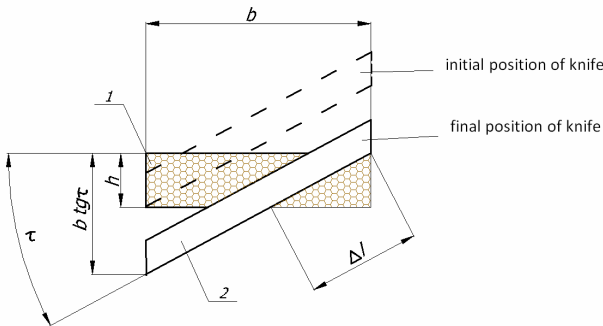

Fig. 4. Cutting of the layer (phase II): 1 – layer of stalks, 2 – knife of the cutting drum,

So, the operation of cutting in phase II is described by dependence:

$$L_{nII} = \frac{C}{r} \int_h^{b t g \tau} \frac{h}{\sin \tau} dx = \frac{C}{r} \frac{h}{\sin \tau} (b t g \tau - h). \quad (10)$$

III PHASE: getting of the knife out of the layer (active knife's length Δl decreases).

Pursuant to the fig. 5, cutting in phase III takes place within the range $b t g \tau \leq x \leq h + b t g \tau$, that is along the same length as in phase I.

Within the range $b t g \tau \leq x \leq h + b t g \tau$, the value

$$\Delta l = \frac{x - b t g \tau}{\sin \tau}.$$

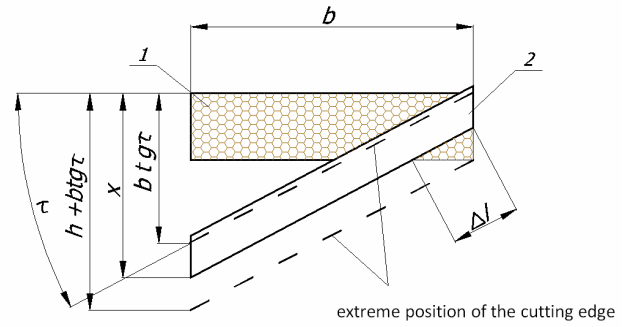

Fig. 5. Getting of the knife out of the layer (phase III): 1 – layer of stalks, 2 – knife of the cutting drum

So, due to that, the cutting operation in phase III is described by dependence:

$$L_{nIII} = \frac{C}{r} \int_{b t g \tau}^{h + b t g \tau} \frac{(x - b t g \tau)}{\sin \tau} dx = L_{nl} = \frac{C}{r} \frac{h^2}{2 \sin \tau}. \quad (11)$$

So, the total operation performer by the knife during one passage through the layer of the cut material shall be expressed by the formula:

$$L_n = L_{nl} + L_{nII} + L_{nIII} = \frac{C}{r} \left(\frac{h^2}{2 \sin \tau} + \frac{h b t g \tau}{\sin \tau} - \frac{h^2}{\sin \tau} + \frac{h^2}{2 \sin \tau} \right) = \frac{C}{r} \frac{h b}{\cos \tau} \quad (12)$$

Substituting for the formula (12) the expression $C = p_c r \cos \tau (1 + \mu t g \tau)$ we receive the expression for the whole cutting operation L_n , performer by the knife at the time of getting through the layer of the material:

$$L_n = h b p_c (1 + \mu t g \tau). \quad (13)$$

It results from the formula (13), that operation performer by the knife during one passage through the layer of the plant material depends on the area of the layer's section expressed by the product $h b$, the unit cutting resistance p_c , angle of sliding cut τ and knife's friction coefficient against the layer μ .

It results from the above considerations also, that operation L_n does not depend on how many knives are operating simultaneously in the layer. In order to determine whether in a given layer there shall operate one or more knives, one may use the following formula:

$$s = h + b t g \tau - \frac{2 \pi r}{z}. \quad (14)$$

For $s \leq 0$ the layer of material is cut by only one knife, for $s > 0$ the layer is simultaneously cut by more knives.

Assuming, that the number of drum's knives amounts to z , where each time the layer is cut by only one knife, we

shall get the formula for the mean moment $(M_c)_{sr}$, operating on the cutting drum's shaft:

$$(M_c)_{sr} = \frac{L_n z}{2\pi}, \quad (15)$$

where -

L_n - operation made by the chaff cutter's knife during one passage through the layer of plant material

z - number of cutting drum's knives.

Substituting for the dependence (13) the formula (15) we get the formula for the mean cutting moment $(M_c)_{sr}$, operating on the cutting drum's shaft:

$$(M_c)_{sr} = \frac{z h b p_c (1 + \mu \cdot t g \tau)}{2\pi}. \quad (16)$$

According to the formula (16) the mean moment on the cutting drum's shaft $(M_c)_{sr}$ depends on the number of knives z , area of the surface of the layer's section hb , coefficient of knife's friction against the plant material μ , the unit cutting resistance p_c and the angle of the sliding cut τ . In order to assure the uniform conveyance of power from the power transmission system to the drum cutting unit and to avoid excessive fluctuations of the drum shaft's angular speed, the starting torque of the drum M_R has to be big enough to give the cutting drum the necessary angular acceleration

$\varepsilon = \frac{d\omega}{dt}$, which is one of the constructional parameters of the cutting unit.

Knowing the value of the moment of inertia J_b of the applied construction of the cutting drum and the value of the angular acceleration $\frac{d\omega}{dt}$ it shall be possible to determine the starting torque M_R of the cutting drum - necessary to overcome the inertial forces.

The starting torque M_R shall then be expressed with the formula:

$$M_R = (M_c)_{sr} = J_b \frac{d\omega}{dt}. \quad (17)$$

Determination of the value of the angular acceleration $\frac{d\omega}{dt}$ for a given construction of the cutting unit, requires the knowledge of the predicted loadings during their cutting.

From the comparison of the formulas (15) and (17) it results that:

$$\frac{2\pi(M_c)_{sr}}{z} = L_n. \quad (18)$$

Assuming $(M_c)_{sr} = J_b \frac{d\omega}{dt}$, after transformation we shall get:

$$\frac{d\omega}{dt} = L_n \frac{z}{2\pi J_b}. \quad (19)$$

Due to that it may be found, that there occurs the linear dependency between $\frac{d\omega}{dt}$ and L_n . The remaining

expression, i.e. $\frac{z}{2\pi J_b}$ shall have the constant value C_k for the given construction of the cutting unit.

Considering that angular acceleration $\frac{d\omega}{dt}$, for a given construction of the cutting drum is the function of the cutting operation L_n , calculated for quasi-statistical conditions.

3. Conclusion

Making an attempt to represent the process of stalks' cutting with the use of the drum cutting unit, an own mathematical mode was drawn up. The novelty of the drawn up process results of the fact that it considers all the phases of the process of plant material layer's cutting - stalks, and makes it possible to determine the cutting operation during these phases and to establish the starting torque of the cutting drum.

The drawn up mathematical model may be called an adequate one in case of positive experimental verification. An adequate mathematical model is important for speeding up of the process of designing new constructions of cutting drums. It is very important due to seasonal character of works in farming what results in the fact, that in spite of in many cases many years experimental studies, the bank of information sufficient for quick designing of this type of working units cannot be established.

4. References

- [1] Bochat A.: Teoria i konstrukcja zespołów tnących maszyn rolniczych. Wydawnictwa Uczelniane Uniwersytetu Technologiczno-Przyrodniczego w Bydgoszczy, Bydgoszcz, 2010.
- [2] Bochat A.: Fazy i model cięcia bębnowym zespołem tnącym. Inżynieria i Aparatura Chemiczna, 2008, nr 5, s. 9-11.
- [3] Bochat A., Błaszczak M.: Problematyka badawcza procesu cięcia warstwy żdźbeł i łodyg. Inżynieria i Aparatura Chemiczna, 2007, nr 1, s. 28-30.
- [4] Bochat A., Zastempowski M.: Kinematics of drum movement of the cutting of a straw cutter. Journal of Polish CIMAC, Volume 7, No 3, 2012, s. 11-16.
- [5] Haffert A. Harms H.H.: Schnitvorgang im Feldhäckslern. Landtechnik, 2002, nr 2, s. 106-107.
- [6] Heinrich A.: Häckselmesser und Gegenschneide eines Feldhäckslers. Landtechnik, 2000, 55(8), s. 440-441.