

EXPERIMENTAL AND SIMULATION RESEARCH OF FORCES AND STRESSES ACTING ON THE HOE COULTER

Summary

The main aim of the experiment was to determine in the laboratory conditions forces acting on the hoe coulters. The measurements were carried out on an abrasive test unit type "rotating bowl" unit using designed and built measuring system. The velocity of the coulters was in the range of 1,11 to 2,22 $m \cdot s^{-1}$, and the depth of penetration into the river sand was 40 or 60 mm. On the basis of the designated forces a computer simulation of stresses and displacements of the coulters tip was carried out. The obtained results made it possible to know the relation between aggravating forces, velocity and depth of immersion of the coulters in the soil, which can be used to calculate wear rates or the coulters levers strength.

Key words: agricultural machinery, coulters, forces and stresses, computer simulation

BADANIA EKSPERYMENTALNE I SYMULACYJNE SIŁ I NAPRĘŻEŃ DZIAŁAJĄCYCH NA REDLICĘ

Streszczenie

Głównym celem przeprowadzonego eksperymentu było wyznaczenie w warunkach laboratoryjnych sił działających na redlicę, która przemieszczała się z prędkościami liniowymi w zakresie od 1,11 do 2,22 $m \cdot s^{-1}$, a jej zagłębienie w piasku rzeczny wynosiło 40 lub 60 mm. Pomiary przeprowadzono na stanowisku, do badań elementów maszyn pracujących gruncie, typu „wirująca miska” z wykorzystaniem zaprojektowanego i zbudowanego układu pomiarowego. Na podstawie wyznaczonych sił przeprowadzono symulację komputerową naprężeń i przemieszczenia redlicy. Uzyskane wyniki pozwoliły na poznanie zależności pomiędzy siłami obciążającymi układ, a prędkością i głębokością redlicy podczas pracy w środowisku gruntowym. Uzyskane dane mogą być wykorzystane zarówno do obliczenia nacisków gruntu na powierzchnię redlicy w celu wyznaczenia intensywności zużywania ściernego jak i do obliczeń wytrzymałościowych dźwigni redlicznych.

Słowa kluczowe: maszyny rolnicze, redlice, siły i naprężenia, symulacja komputerowa

1. Introduction

Elements of agricultural machines often work in harsh conditions. Thus the problem of forces and stresses occurring during their work, especially for the elements working in the soil is still valid and is taken by many researchers to improve the durability and reliability of agricultural machinery by different methods [1, 2, 4, 5, 8].

Research studies of wear process of machine elements are conducted both in the laboratory and field (operating) conditions [7]. Laboratory tests were performed on a specially prepared for this research test unit. Through this analysis information on the behavior of cooperating objects in real conditions were obtained. Depending on the stage of the research, they allow a fairly detailed analysis of the phenomena occurring between cooperating components, and relatively low cost compared with field reliability research is their main advantage [6].

The main goal of the research presented in this article is to identify the relationship between the forces acting on the coulters and its operating velocity, cutting depth of the coulters in the soil. Coulters on the "spinning bowl" test bench were examined. Forces generated by an established line velocity and depth of immersion were determined. In the next step simulation study was conducted, which allowed to determine the stresses and displacements of the coulters. The determined force can be used for calculation or determination of the coulters strength, pressure acting on the coulters to estimate the intensity of its abrasive wear.

2. Experimental study

Experimental research of the coulters used in seeder "Poznaniak" manufactured by "Famrol" on "rotating bowl" unit was carried out (Fig. 1). The main element of the abrasive test unit consists of bowl with the soil, driven by the transmission. The angular velocity of the test unit can be adjusted in the range of 0 to 2,83 $rad \cdot s^{-1}$, which enables the linear velocity of the tested tool up to 2,78 $m \cdot s^{-1}$.

The advantage of the test unit consists in the ability to change the properties of soil placed in the bowl by soil compacting with a roll pressure regulated by two screw cylinders. The soil can be cultivate, using the three steel teeth. Moisture of the soil is regulated by the sprinklers. The main parameters of the "rotating bowl" unit are:

- load capacity 1000 kg,
- sheet thickness 3 mm,
- capacity 0,56 m^3 ,
- diameter 1600 mm,
- angular velocity 0-2,83 $rad \cdot s^{-1}$.

River sand was selected as the abrasive medium. Following a grain size analysis, the grain size distribution curve was determined. The choice of river sand was based on a high proportion of quartz particles as compared to other types of soil, thus making this medium particularly abrasive. The medium selected for this study underwent sieve analysis. After sieving 1000 g of soil the grain size distribution curve was determined for the sand fraction. The re-

maining dust fraction (less than 5 g) was considered insignificant. The gravel fraction constituted approximately 2,5% of the tested medium. An analysis of the grain size distribution curve indicates that one deals here with medium sand with a very low share of gravel and dust fractions (less than 3%). Sand was used as abrasive material, with grain fraction at 0,2–0,3 mm, and hardness at $995 \pm 10\%$ HV, while the abrasive material supply rate was set at the level of $0,5 \text{ g/cm}^2 \cdot \text{s}$. The sand was selected in accordance with the PN-EN 933-1:2001 standard. In order to get the right fraction and dispose of dust and organic pollutants, the sand was flushed, and a sieve analysis was performed, according to the PN-H-04188:1997 standard.

The measuring system fixed on the "rotating bowl" unit,

consisted of two sensors produced by ZEMIC company. They were connected to a signal amplifier Spider 8, made by HBM company. The amplifier is powered from a battery. The voltage converter AC/DC allowed for voltage change from 230 to 12 V. The use of the transducer was necessary because of the noise generated by the inverter, which regulates the rotation of the test unit for coulter immersed in the soil. For identical reason, the computer was powered by a built-in battery. The amplifier Spider 8 has only analog outputs RS32, so it was necessary to use an adapter RS32 - USB. Diagram of the measuring system was shown in Fig. 2, the coulter attachment and sensors were presented in Fig. 3 and in Fig. 4 the measuring system on the position was presented.

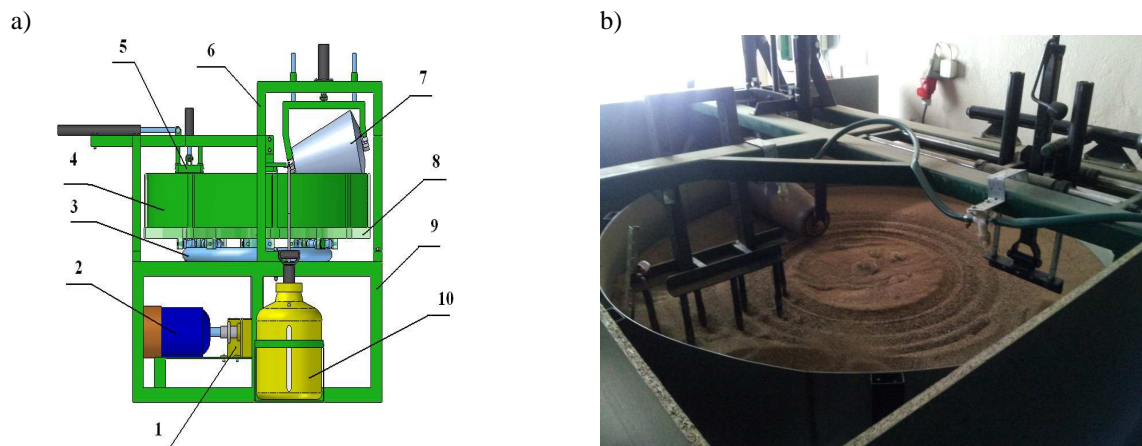

Fig. 1. The "rotating bowl" unit: a) Scheme [3]: 1 - transmission, 2 - engine, 3 - running rail, 4 - bowl, 5 - holder of the sample, 6 - supporting frame, 7 - roller: 8 - frame of the bowl, 9 - main frame, b) view [9]

Rys. 1. Stanowisko badawcze „wirująca miska”: a) Schemat [3]: 1 – przekładnia ślimakowa, 2 – silnik, 3 – szyna jezdna, 4 – miska, 5 – uchwyt próbki, 6 – rama pomocnicza, 7 – walec ugniatający, 8 – rama misy, 9 – rama główna, b) widok [9]

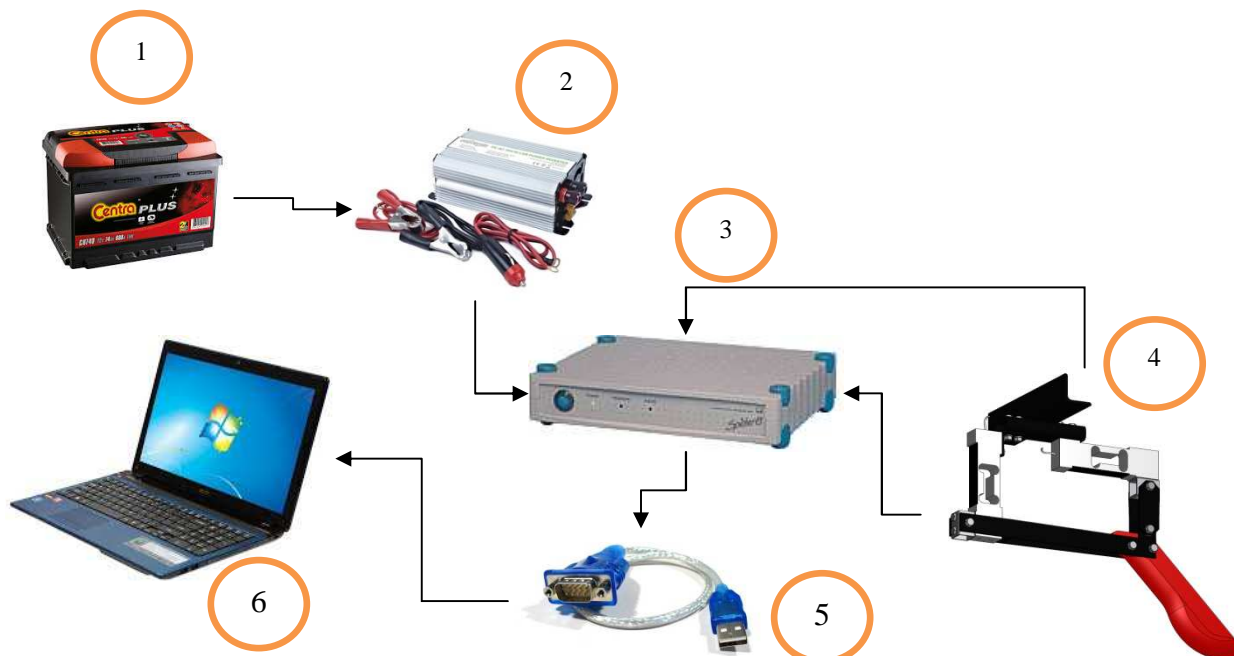

Fig. 2. Diagram of the measuring system used during the implementation of the research [9]: 1 - battery, 2 - converter, 3 - amplifier HBM Spider 8, 4 - test stand fitted with the hoe coulter and sensors, 5 - signal converter, 6 - computer

Rys. 2. Schemat układu pomiarowego wykorzystywanego podczas realizacji badań [9]: 1 – akumulator, 2 – przetwornica, 3 – wzmacniacz sygnału HBM Spider 8, 4 – stanowisko badawcze z zamocowaną redlicą i czujnikami, 5 – konwerter sygnału, 6 – komputer

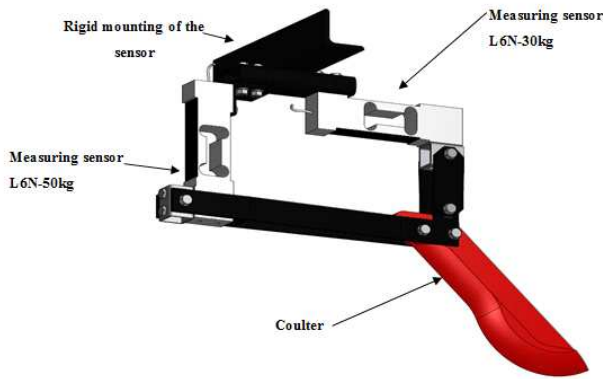

Fig. 3. The model of the measuring system used to measure the force on the hoe coulter [9]

Rys. 3. Model układu pomiarowego wykorzystywanego do pomiaru siły działającej na redlicę [9]



Fig. 4. The measuring system used to measure the force on the hoe coulter [9]

Rys. 4. Układ pomiarowy wykorzystywany do pomiaru siły działającej na redlicę [9]

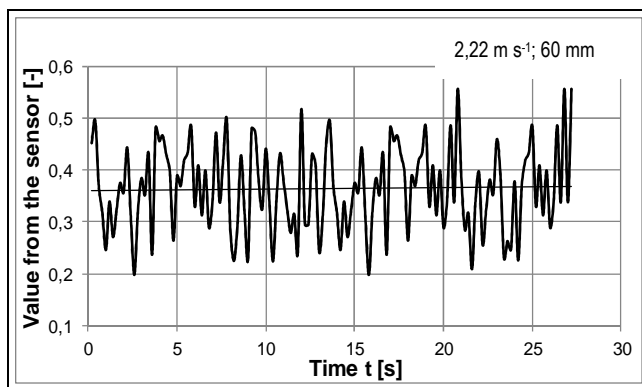

Fig. 5. A piece of a single measurement obtained during the tests for speed of $2,22 \text{ m}\cdot\text{s}^{-1}$ and cutting depth of the coulter of 60 mm [9]

Rys. 5. Fragment pojedynczego pomiaru uzyskany podczas realizacji badań dla prędkości $2,22 \text{ m}\cdot\text{s}^{-1}$ i głębokości skrawania redlicy 60 mm [9]

The measuring stand allows to measure the force acting on the coulter tip for two of its depths of penetration (40 and 60 mm) and different linear velocities in the range of $1,11$ to $2,22 \text{ m}\cdot\text{s}^{-1}$. A sample piece of the measured value acting on the sensor in one direction was shown in Fig. 5.

The results have a rather significant scatter of measurement value due to vibration, which fell into the system under investigation. It was caused by the abrasive wear test unit because lateral force generated by rotating sand works on the coulters.

Based on the results from the sensors, component of force values and resultant force acting on the coulter tip for different linear velocities and the cutting depth of the hoe coulter into the soil were calculated (Fig. 7-9). The values of the forces calculated on the basis of a simplified distribution of forces in the system are shown in Fig. 6.

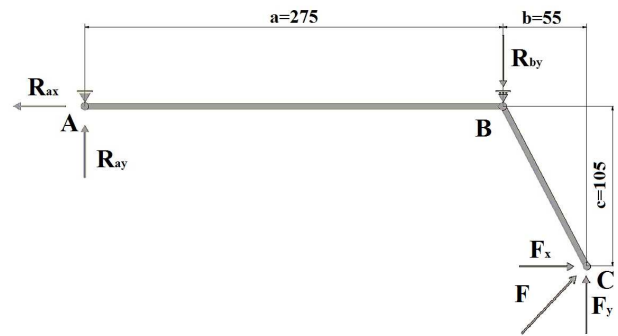

Fig. 6. Simplified distribution of forces in the measuring system [9]

Rys. 6. Uproszczony rozkład sił w układzie pomiarowym [9]

The single beam on the right side by the pivotal joint and on the left side by moving joint was supported. So the following formula (1-3) can be written [9]:

$$x: -R_{ax} + F_x = 0 \Rightarrow F_x = R_{ax} \quad (1)$$

$$y: R_{ay} - R_{by} + F_y = 0 \Rightarrow F_y = R_{by} - R_{ay} \quad (2)$$

$$M_b: -R_{ay} \cdot a + F_y \cdot b + F_x \cdot c = 0 \Rightarrow F_y = \frac{R_{by} \cdot a - F_x \cdot c}{a+b} \quad (3)$$

If the R_{ax} means the L6N-50kg and R_{by} L6N-30kg sensor and also if it is known the distance between the points of application of the force we can determine the following relationships (4-5):

$$F_x = R_{ax} \quad (4)$$

$$F_y = \frac{R_{by} \cdot 275 - R_{ax} \cdot 105}{330} \quad (5)$$

Substituting the data for received dependences the force values for all test cases were obtained. A resultant force F was calculated from the formula (6):

$$F = \sqrt{F_x^2 + F_y^2} \quad (6)$$

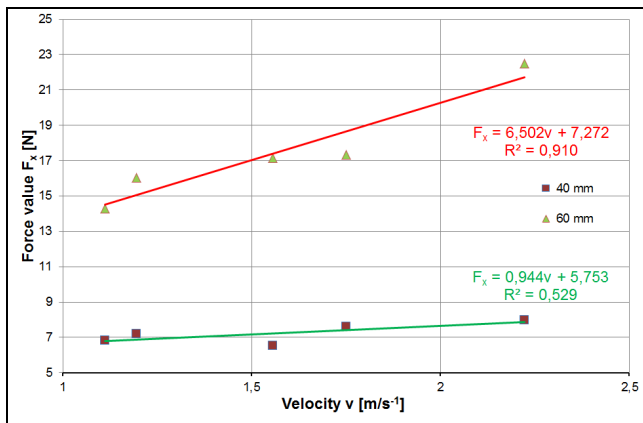

Fig. 7. F_x force acting on the hoe coulter [9]
Rys. 7. Wartości siły składowej F_x działająca na redlicę [9]

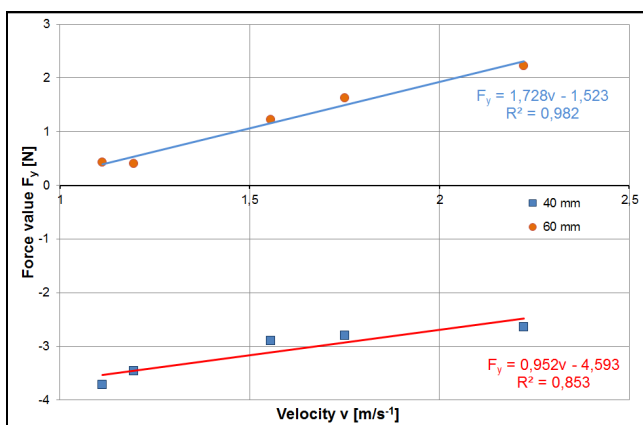

Fig. 8. F_y force acting on the hoe coulter [9]
Rys. 8. Wartości siły składowej F_y działająca na redlicę [9]

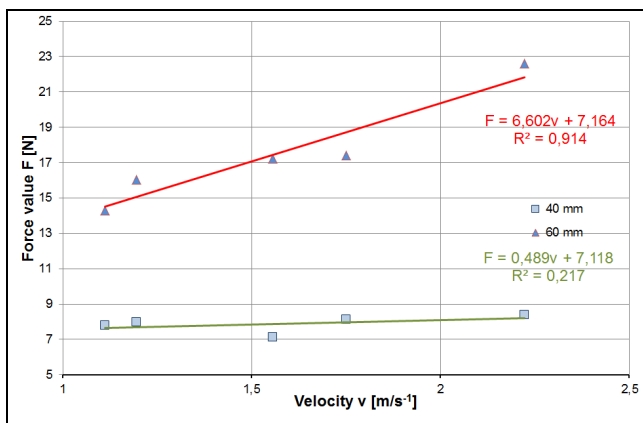

Fig. 9. The values of the resultant force F acting on the hoe coulter [9]
Rys. 9. Wartości siły wypadkowej F działająca na redlicę [9]

With the increase in the coulter velocity in the soil on the "rotating bowl" unit, mounted that there was an increase in forces acting on the tip. Negative value of the force in the vertical direction that occurs in cutting depth of 40 mm for a component F_y is also important. This means that the component "y" of the force F is less than the weight of the test system. The resultant force F acting on the coulter tip in both cases of coulter depth of penetration into the soil is growing. This increase is significant in the case of the penetration of 60 mm. For speed of 1,11 m·s⁻¹ value is 14,29 N, whereas for the 2,22 m·s⁻¹ is more than 22,5 N.

This gives an increase by less than 60% of the velocity growth about 100%. From the graphs can also be noted that in the case of horizontal forces to 2,22 m·s⁻¹ is a significant forces increase compared to the previous presented velocity. So a significant increase in resultant force is not reported for work at a depth of 40 mm. The resultant value, in this case fluctuates at a similar level of 8 N, with a slightly increasing trend with growing up velocity of the coulter in the soil. This is due to the direction of the vertical force at a lower immersion in the soil.

3. Computer simulation

The simulation tests were performed using a computer program Inventor 2014 in which shape of the coulter was modeled, and the coulter by pin bonds in a fixing spot was fixed. Based on the results of the forces acting on the coulter tip obtained in experimental studies and presented in the previous section, modeled them in a computer program, assuming the velocity of 8 km·h⁻¹ and penetration of the coulter into soil - 60 mm (Fig. 10). Because coulters were made of spheroidal graphite (cast) iron, the model assigned to the properties of that material (e.g. Young's modulus of elasticity, Poisson's ratio, etc.).

As a result of computer simulation of the forces acting on the coulter during operation in the soil, both a displacement of the coulter (Fig. 11), as well as the von Mises stress were determined (Fig. 12).

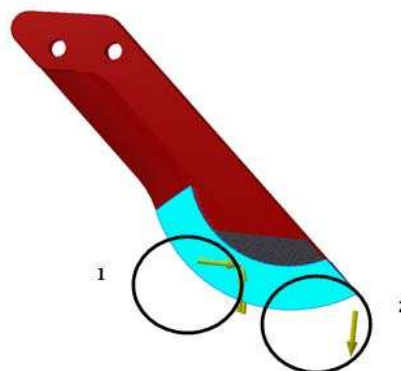

Fig. 10. Model of the coulter made in Autodesk Inventor, along with forces: 1 - forces acting on the coulter resulting from pressure of the soil, 2 - the force of gravity [9]

Rys. 10. Model redlicy wykonany w programie Autodesk Inventor wraz z zadanymi siłami: 1 – siły działające na redlicę wynikające z nacisku gleby, 2 – siła grawitacji [9]

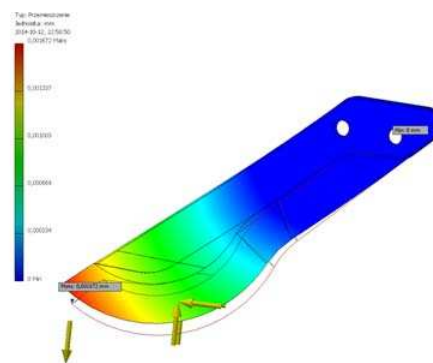

Fig. 11. Determined displacement of the coulter based on computer simulation [9]

Rys. 11. Przesunięcie redlicy w układzie wyznaczone na podstawie symulacji komputerowej [9]

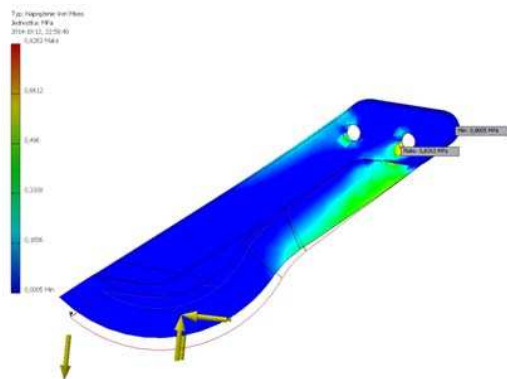

Fig. 12. Von Mises' stresses determined based on computer simulation [9]

Rys. 12. Naprężenia Von Misesa wyznaczone na podstawie symulacji komputerowej [9]

Based on computer simulation it must be stated that the greatest displacement occurs for coulters around its tip, which may indicate a high stiffness of the tool - higher than the forces acting on it. The obtained values of displacements, both the maximum and minimum are small. The greatest stress is obtained at the place of fixing tip of the coulters on the test unit, while for the remaining area of the parts is low. On the basis of simulation studies it should be noted that the stress occurring in the coulters - soil system, even at high line speed and the depth of penetration of the coulters at the level of 60 mm are much lower than the permissible stresses for iron cast, which is the material from the coulters tip was made.

4. Proposals of modification for further research

The study allowed to design and construct the measuring system of forces acting on the tool (coulters), which works in the soil. Nevertheless, the proposed measuring system should be modified. Reducing the lateral force acting on the coulters in the soil requires fitting it close to diameter of the test unit (Fig. 13), through the use of the long arm, suitably reinforced (rigid). Such location will allow to minimize lateral forces acting on the tool, which will cause more stable changes of the measured parameters than it was during the presented study (Fig. 4).

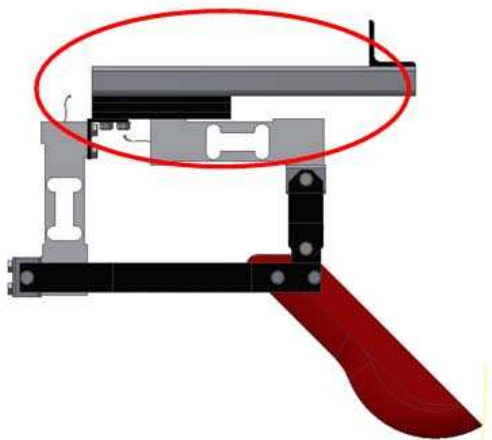

Fig. 13. The proposal of change of the attachment location of the measuring system reducing effect of the lateral force [9]

Rys. 13. Propozycja zmiany miejsca mocowania układu pomiarowego niwelujący wpływ siły bocznej [9]

That force can not be eliminated entirely, because the coulters on test unit moves in a circular motion. The results of the forces, determined by the test unit should be related to the wear of the tested elements which worked in soil for a specified time and completed a predetermined number of kilometers. This allows to find the relationship between forces occurring in the system coulters - soil and optimization of its working conditions (working speed, cutting depth) in soil. Another step of experimental studies should determine forces and wear values for the other speed of operation of the coulters, e.g., 2, 4, 6 $\text{km}\cdot\text{h}^{-1}$.

5. Conclusions

On the basis of experimental and computer simulation research it can be stated that:

- designed and manufactured measuring system allows to measure the forces acting on the tip of the coulters, which works in the soil,
- conclusions from research have led to the modification of the measuring system, which could reduce the impact of lateral force acting on the coulters,
- obtained during research forces acting on the coulters and velocity of its work in the sand (cutting depth 60 mm) were characterized by a high value of determination coefficient,
- the results of the forces acting on the coulters will be useful to calculate the strength of the coulters' lever in the case of designing a new seeder and allow to estimate the pressure from the surface of the soil used to calculate the amounts of wear of the coulters.

Studies using the "rotating bowl" unit led to designation of the forces acting on the coulters working in the sand. In the next stage of the study it is planned by the authors of this paper to define the relation between forces acting on the coulters and its wear.

6. References

- [1] Bartkowski D., Kinal G., Didziak B., Piasecki A., Matysiak W.: Microstructure and wear resistance of stellite-6/wc metal matrix composite coatings. *Journal of Research and Application in Agricultural Engineering*, 2015, 60(2), 21-25.
- [2] Bartkowski D., Młynarczak A., Gościański M.: The Effect of Diffusion Boriding on Durability of the Agricultural Tools Used in the Soil. *Archives of Mechanical Technology and Automation*, 2012, 32, 7-14.
- [3] Biadała P.: Projekt stanowiska do badania zużycia elementów maszyn roboczych pracujących w ośrodku glebowym. Praca dyplomowa. IMRiPS, Poznań, 2007.
- [4] Dudziak B., Gościański M.: The influence of selected metal powder laser cladding parameters on the C45 steel on the aspect of hardness changes. *Journal of Research and Applications in Agricultural Engineering*, 2012, 57(1), 29-33.
- [5] Foley A.G., McLees V.A.: A comparison of the wear of ceramic tipped and conventional precision seed drill coulters. *Journal of Agricultural Engineering Research*, 1986, 2, 97-113.
- [6] Hebda M., Wachal A.: Trybologia. Wydawnictwo Naukowo-Techniczne, Warszawa, 1980.
- [7] Kostencki P.: Polowe badania intensywności zużycia wybranych gatunków stali. *Inżynieria Rolnicza*, 2008, 4, 405-413.
- [8] Natsis A., Papadakis G., Pitsilis J.: The Influence of Soil Type, Soil Water and share Sharpness of a Mouldboard Plough of Energy Consumption, Rate of Work and Tillage Quality. *Journal of Agricultural Engineering Research*, 1999, 72, 171-176.
- [9] Spiczak-Brzeziński P.: Zależność siły od głębokości i prędkości pracy narzędzia pracującego w ośrodku ściernym. Praca dyplomowa. IMRiPS, Poznań, 2014.