

## THE ANALYSIS OF MECHANICAL DAMAGE OF COMMON RAIL INJECTORS

### Summary

The paper presents the causes and effects of corrosion, destructively affecting the technical condition and operational reliability of injectors used in Common Rail supply systems. In addition, the analysis was made regarding damage to compression-ignition (diesel) engines with common-rail supply systems occurring in the operation of injectors caused by external and internal operating factors. Studies on injection equipment wear were carried out with the use of Hitachi S-3400 scanning electron microscope. Photos were also taken at the repair workshop of the needle surface and the socket using D.O. Smart digital microscope with specialized fibre optic lighting. Worn components were analyzed, indicating the elements most frequently subject to destructive processes. The possibilities of diagnosing subassemblies of Common Rail injection systems were indicated.

**Keywords:** Common Rail supply system, fuel injectors, consumption, types of diagnostics

## ANALIZA USZKODZEŃ MECHANICZNYCH WTRYSKIWACZY COMMON RAIL

### Streszczenie

W artykule przedstawiono przyczyny i skutki korozji, wpływającej destrukcyjnie na stan techniczny oraz niezawodność eksploatacyjną wtryskiwaczy stosowanych w układach zasilania Common Rail. Ponadto dokonano analizy uszkodzeń silników o zapłonie samoczynnym z układami zasilania typu Common Rail występujących w pracy wtryskiwaczy spowodowanymi zewnętrznymi i wewnętrznymi czynnikami eksploatacyjnymi. Przeprowadzono badania zużytej aparatury wtryskowej z zastosowaniem skaningowego mikroskopu elektronowego Hitachi S-3400. Wykonano również zdjęcia w serwisie zajmującym się naprawą powierzchni iglicy i gniazda mikroskopem cyfrowym D.O. Smart ze specjalistycznym oświetleniem światłowodowym. Analizie poddano zużyte części składowe, wskazując na elementy najczęściej ulegające procesom niszczącym. Wskazano na możliwości diagnozowania podzespołów układów wtryskowych Common Rail.

**Słowa kluczowe:** układ zasilania Common Rail, wtryskiwacze paliwa, zużycie, rodzaje diagnozowania

### 1. Introduction

Common Rail (CR) fuel supply systems have become the most popular system used in compression-ignition (diesel) engines. Common Rail high-pressure injection systems generate pressures of over 200 MPa, and interoperate with electromagnetic and piezo injectors made by: Bosch, Delhi, Denso, Continental (Siemens) [4, 9, 11].

CR supply systems include three basic functional blocks:

- low pressure circuit,
- high pressure circuit,
- electronic control system with sensors, controller and adjusters (actuators).

Fig. 1 shows the most important assemblies of this CR supply system. Due to the multi-phase and precise fuel injection, they have replaced other solutions, enabling to obtain very good technical parameters of the engine with low specific fuel consumption and exhaust toxicity. Stringent Euro 6 exhaust gas emissions standards in force from 2014, which define the acceptable standards of NO<sub>x</sub> up to 400 mg, i.e. 80% less than the EURO V standard, solid particulates up to 10 mg/KWh, i.e. 66% less than the Euro 5 standard, place high demands on the injection equipment [10, 12]. The problem has been solved in several ways, including the introduction of multi-phase fuel injection per

cycle, exhaust gas recirculation valves and probably the most troublesome for most users – a diesel particulate filter.

The injectors used in these supply systems are directly subjected to pulsed loads with pressure of 200 MPa and thermal loads that have a direct impact on engine efficiency, performance, fuel consumption and emissions of harmful exhaust gas components into the atmosphere. The task of the injector is to inject fuel through the nozzle in a very short time of a few thousandths of a second into the combustion chamber and at the appropriate pressure. Injectors are electrically controlled, so they can quickly react to signals from the controller. All of these improvements have allowed to measure the injected fuel by the opening time of the injectors, as well as to divide the injected fuel portion into smaller doses: pilot injection, main injection and post-injection. The first and second generation Common Rail systems had electromagnetic injectors. A piezo injector appeared in the third generation of Common Rail systems. Its main advantage is a short switching time of approx. 0.1 ms. This is about ten times faster than electromagnetic injectors. This enables to freely control the start of injection and the amount of fuel, and to perform multiphase injection. The fuel pressure is increased in systems where the piezoelectric injector is used and can exceed 200 MPa. Fig. 2 shows the construction of a typical electromagnetic injector.

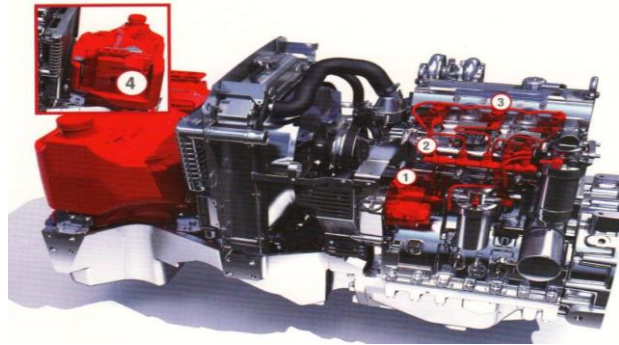

Fig. 1. The most important Common Rail fuel system assemblies in the MF-3600 tractor engine, 94 HP [70 kW]: 1 - high pressure supply pump, 2 - Common Rail, 3 - injectors, 4 - electronic control unit (ECU) responsible for controlling the system [6]

Rys. 1. Najważniejsze zespoły układu paliwowego Common Rail silnika ciągnika MF-3600 o mocy 94 KM [70KW]: 1 – pompa zasilająca wysokiego ciśnienia, 2 – szyna Common Rail, 3 – wtryskiwacze, 4 – elektroniczna jednostka sterująca ECU odpowiadająca za kontrolę i sterowanie układem [6]

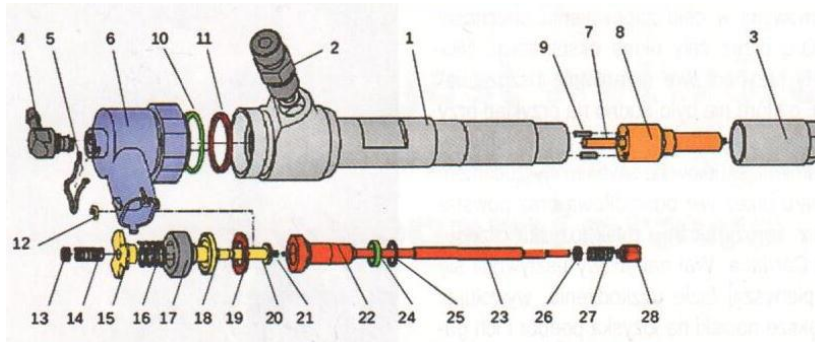

Fig. 2. Assembly diagram of the Common Rail electromagnetic injector [16]: 1 - nozzle-holder body, 2 - fuel supply connector, 3 - nozzle retaining nut, 4 - overflow spigot, 5 - clamping saddle, 6 - solenoid coil, 7 - pressure pin, 8 - nozzle body, 9 - locating pins, 10 - gasket, 11 - washer, 12 - cotter, 13 - spring washer, 14 - valve spring, 15 - electromagnet jumper, 16 - spring, 17 - valve guide, 18 - washer, 19 - washer, 20 - valve pusher, 21 - ball guide, 22 - the body of the control chamber, 23 - bucket increaser, 24 - gasket of the control chamber, 25 - washer, 26 - spring washer of the needle, 27 - needle spring, 28 - stem of the needle

Rys. 2. Schemat złożeniowy wtryskiwacza elektromagnetycznego Common Rail [16]: 1 – korpus wtryskiwacza, 2 – króciec dolotu paliwa, 3 – nakrętka rozpylacza, 4 – króciec przelewu, 5 – zawleczka, 6 – cewka elektrozaworu, 7 – iglica, 8 – korpus rozpylacza, 9 – kolki ustalające, 10 – uszczelka, 11 – podkładka, 12 – zawleczka, 13 – podkładka sprężynowa, 14 – sprężyna zaworu, 15 – zwora elektromagnesu, 16 – sprężyna, 17 – prowadnica zaworu, 18 – podkładka, 19 – podkładka, 20 – popychacz zaworu, 21 – zespół kulki zaworu, 22 – korpus komory sterującej, 23 – popychacz sterujący, 24 – uszczelka komory sterującej, 25 – podkładka, 26 – podkładka sprężyny iglicy, 27 – sprężyna iglicy, 28 – trzonek iglicy

## 2. Research methodology

The object of the research were CR injectors in the number of 122 units made by Bosch, Delphi, Denso, and Siemens. The purpose of the research was to analyze the influence of fuel quality on the consumption of selected elements of the Common Rail system. The essential condition for the study was washing the injectors in ultrasonic washers. They were then dried and thoroughly blown with compressed air. Visual inspection and verification of individual elements were carried out on a stand with Hitachi S-3400 scanning electron microscope, and with the use of D.O. Smart digital microscope with specialized fibre optic lighting. The results of the analysis indicate that the mechanical damage concerns mainly actuation and control elements of Common Rail injectors.

## 3. Results of the research

The results of the analysis indicate that corrosion is a significant factor affecting the failure rate of CR systems. As shown in Fig. 3, the most common type of damage to

injectors of this type was: 34% needle valve, followed by 31% nozzles, 29% control valves in the third place, 4% solenoid valves, and 2% others.

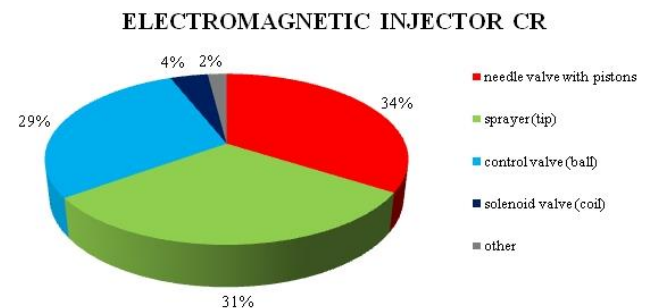

Source: own study / Źródło: opracowanie własne

Fig. 3. Statistics of injectors failures used in high pressure systems CR

Rys. 3. Statystyka uszkodzeń wtryskiwaczy stosowanych w układach wysokiego ciśnienia CR

One of the most frequently detected damage in modern CR injectors is the abrasive wear of a precision pair, which

is a needle with a nozzle, and a needle valve, which is shown in Fig. 4 I and II.



Source: own study / Źródło: opracowanie własne

Fig. 4. Components of Common Rail electromagnetic injectors subject to wear, where: I – nozzle, II – needle valve, III – solenoid assembly with armature

Rys. 4. Elementy składowe wtryskiwacza elektromagnetycznego Common Rail podlegające zużyciu: I – rozpylacz, II – zawór iglicowy, III – zespół elektromagnesu wraz z twornikiem

The first symptoms indicating a deterioration of the interoperation of these components are observed when the engine is on idle (vibrations, noisy combustion process). The fault can be detected at the low pressure set point on the test bench [3], and it concerns the construction of drive units with a relatively low operating mileage. Possible causes include: use of poor quality fuels (too low lubricity) or with too high a share of the vegetable component, improper filtration [1, 2]. The acceptable value for solid contaminants in the fuel is determined according to PNEN 590/2006 to be below 24 mg/kg of fuel. It should be noted that this value was also in force during the widespread use of conventional injection systems and has not changed. Fuel quality, including mainly water and sulphur content, has a significant impact on the intensity of destructive processes. The literature [1, 5, 7] also points to other reasons, including high pressures and temperatures in the combustion chamber, ballistic phenomena, turbulent liquid flow, and cavitation erosion.

Faulty injectors give the following symptoms:

- difficulties during start-up,
- reduced power,
- increased fuel consumption,
- increased smoke emission,
- noisy engine operation,
- uneven idling.

Fig. 4 shows the components of the electromagnetic injector, which are most often subject to wear.

#### 4. Laboratory testing of damaged injectors - metallographic

The test results showed a visible effect of high temperature and pressure on the burnt tip and marks of scorching on the needle. The photographs of the nozzle tip were taken as part of metallographic tests at the Materials Laboratory (LabMaPL) of the Department of Materials Science at the Rzeszow University of Technology with the use of the Hitachi S-3400N scanning electron microscope. At magnifications of 25x, 60x, wear was found, which is related to high thermal loads causing changes in the internal structures of the metal (Fig. 5).

In addition, at a magnification of 25x and 60x, the impact of high temperatures at the tip of the nozzle is visible, leading to changes in the surface structures and melt marks. There are also uneven nozzle bores and damage to nozzle bore edges due to erosion.

At a magnification of 180x and 250x, the tip of the nozzle shows a change in surface structure, the presence of micropores and micro-cracks of varying course and intensity (Fig. 6) below is the wear in control valve seats and on the contact surface of the valve plug. Microscopic images of significant changes in the conical needle and socket surface were taken with the D.O. Smart digital microscope with specialized fibre optic illumination. Damage to the ball valve seat causes an increase in the overflow rate, which leads to incorrect operation of the injector.

The research has shown that the greatest damage concerns the sealing association of the seat and the nozzle cone, where deformations occur as a result of the dynamic action of the needle. Figs. 7-12 shows examples of such damage. Fig. 10 shows the needle and injector tip from the Common Rail system, where traces of local overheating can be seen on the surfaces.

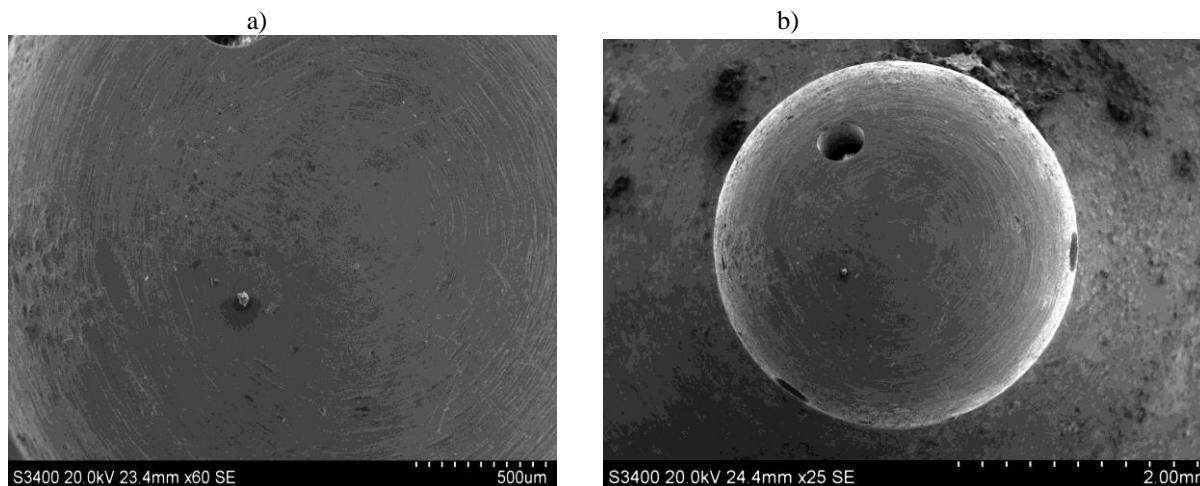

Fig. 5. A photo of the tip of the nozzle at 25x magnification (a) and 60x (b) [16]

Rys. 5. Zdjęcie końcówki rozpylacza w powiększeniu 25x (a) i 60x (b) [16]



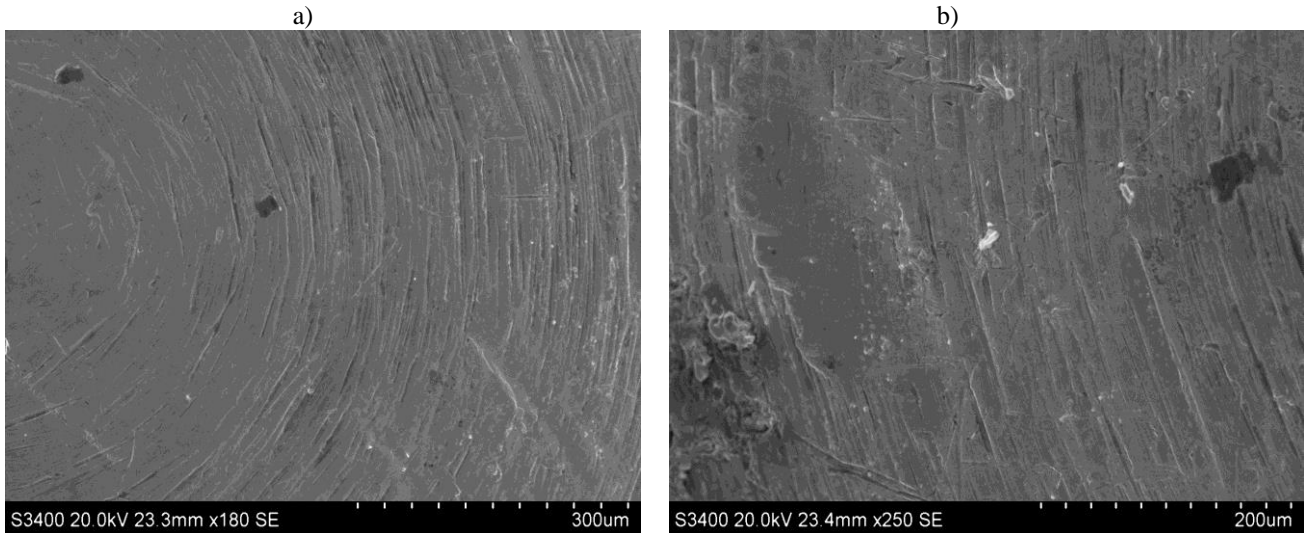

Fig. 6. A photo of the tip of the nozzle at 180× magnification (a) and 250× (b) [16]  
 Rys. 6. Zdjęcie końcówki rozpylacza w powiększeniu (a) 180 × i 250 × (b) [16]

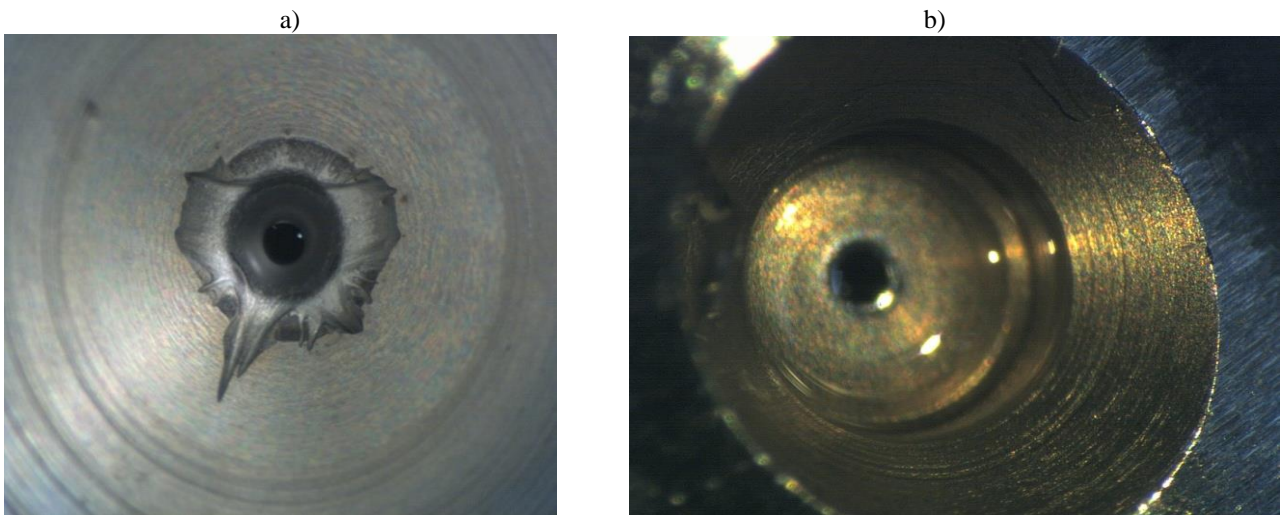

Fig. 7. Unusual surfaces of control seats - erosion of the Bosch injector control valve seat (a), worn surface of the control valve seat (b) [16]  
 Rys. 7. Nietypowe powierzchnie gniazd sterujących - erozja gniazda zaworu sterującego wtryskiwacza firmy Bosch (a), wypracowana płaszczyzna gniazda zaworu sterującego (b) [16]

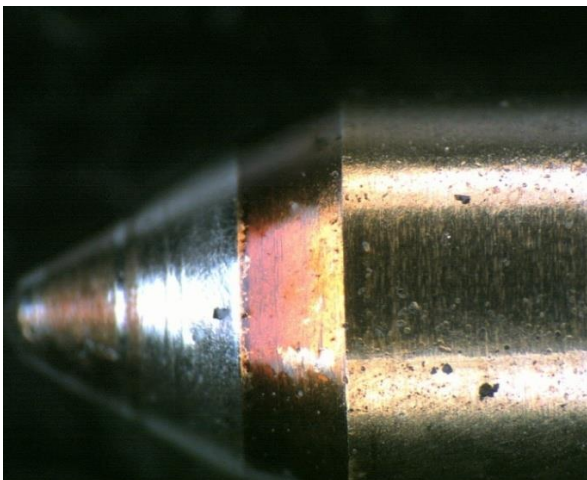

Fig. 8. Deep pitting corrosion of the needle (Bosch Common Rail nozzle) [16]  
 Rys. 8. Głęboka korozja wżerowa iglicy (rozpylacz Common Rail Bosch) [16]



Fig. 9. Carbon in the area of nozzle holes (Bosch Common Rail nozzle) [16]  
 Rys. 9. Nagar w rejonie otworów rozpylających (rozpylacz Common Rail Bosch) [16]



Fig. 10. Nozzle - there are visible signs of strong overheating of the nozzle in the form of brown discoloration, which caused seizure of the needle and blockage of the fuel flow [16]

Rys. 10. Rozpylacz – widoczne są oznaki silnego przegrzania rozpylacza w postaci brązowych przebarwień, co spowodowało zatarcie iglicy i zablokowanie przepływu paliwa [16]

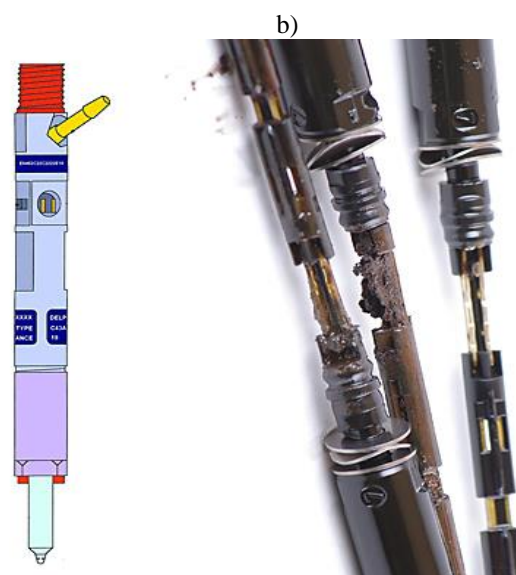

Fig. 11. Plunger with needle valve - dark yellowish coating on the needle valve is visible, due to the use of biofuels and the action of organic acids contained in the fuel [16]

Rys. 11. Popychacz z zaworem iglicowym – widoczny jest ciemny żółtawy nalot na zaworze iglicowym, mający związek ze stosowaniem biopaliw oraz działaniem kwasów organicznych zawartych w paliwie [16]



a)



b)

Fig. 12. Components of the injector (a), damaged coil of the piezo injector (clear traces of corrosion and loss of material caused by water entering the coil through leaking seals (b) [16]

Rys. 12. Elementy składowe wtryskiwacza (a), uszkodzona cewka wtryskiwacza piezo (wyraźne ślady korozji i ubytku materiału spowodowane dostaniem się wody do cewki przez nieszczelne uszczelnienia (b) [16]

In addition to fatigue and erosion-and-friction wear, the injector is subject to wear caused by the so-called flow cavitation. This phenomenon occurs on the contact surface of the nozzle needle with the socket in the body. The damage presented above can lead to additional operational and service problems, as described above.

#### 4.1. Diagnosis of CR injectors

Service procedures clearly state the methods of controlling Common Rail injectors, both electromagnetic and piezoelectric. The basic ones include leakage channel and fuel delivery control at special test stands, e.g. EPS 200 by BOSCH [8] or special test benches, where leakage values per 1000 fuel injection cycles are measured at the required control pressures in the Rail. The Common Rail system is compliant with diagnostic tests due to the presence of an extensive electronic control sub-system. Therefore, testing of all generations of CR injectors boils down to using an

oscilloscope and checking the voltage waveform. Bosch FSA 740 diagnoscope is a suitable diagnostic device for this purpose. It is also possible to measure the resistance of a piezo crystal stack at 100-150V. It is possible to measure the capacity of the piezo crystal stack using a multimeter and the obtained result is compared with the control values given in the injector characteristics. The device shown in Fig. 13 allows comparing the fuel flow rate through the return pipes of individual injectors.

The EDIA-PRO analyzer from Delta Tech Electronics is an excellent one on a global scale, due to its capabilities and affordable price (Fig. 12). This analyzer is a device enabling quick recording of control signals of CR injectors. It allows monitoring the control current of four injectors at the same time by relating their values to the signal from the high pressure sensor placed on the Rail. It allows to perform time-based signal analysis, shape analysis and high-pressure value analysis. Fig. 13 shows an example of a screenshot from the study.



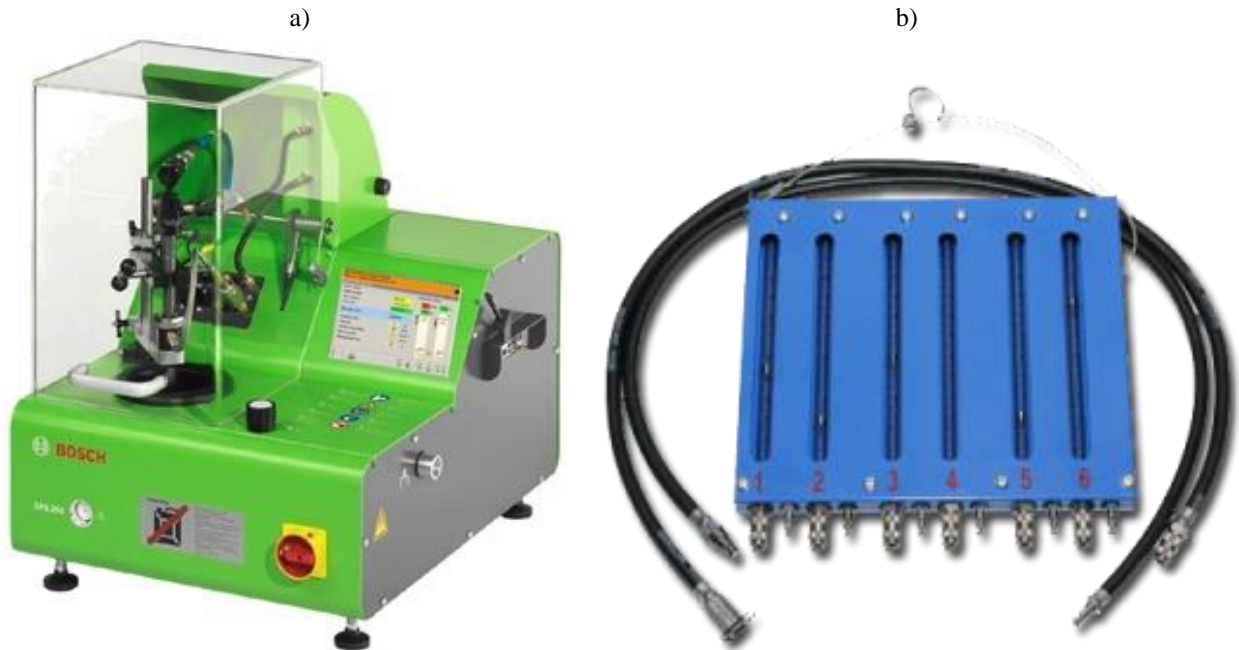

Fig. 13. Electronic injector tester EPS-200 (a); a set for measuring overflows of CR injectors (b) [15, 17]  
 Rys. 13. Elektroniczny próbnik wtryskiwaczy EPS-200 (a), zestaw do pomiaru przelewów wtryskiwaczy CR (b) [15, 17]

Diagnostics of technical condition of Common Rail systems puts high demands on the personnel of authorized workshops. Restoring the original operation of a common rail injector is a task that requires the use of professional equipment as well as maintenance work in suitable, uncontaminated rooms. Benches of this type enable to carry out

complex tests and adjustments (Fig. 14). Test benches equipped with computer hardware enable measurement of parameters of fuel injection delivery. The measurement results are continuously displayed on a computer monitor in digital and graphic form.

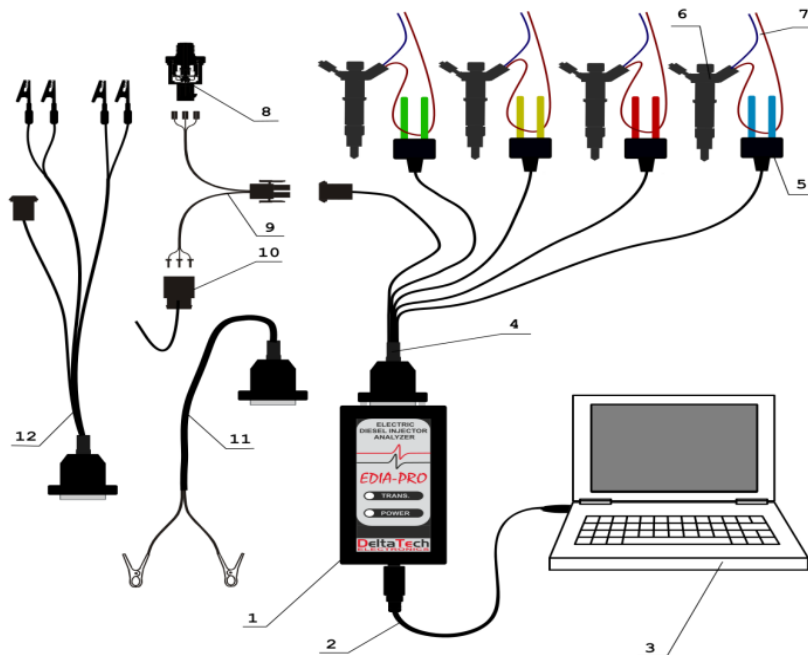

Fig. 14. Diagram of connecting the EDIA-PRO supply for testing the Common Rail system [17]: 1 - device EDIA-PRO, 2 - USB cable, 3 - computer, 4 - measuring cable, 5 - measuring probe, 6 - injector, 7 - injector wires, 8 - high pressure sensor, 9 - Sensor connection cable, 10 - sensor connector in the car, 11 - cable for measuring tension and compression pressure, 12 - cable for measuring control valves

Rys. 14. Schemat podłączenia zasilania EDIA-PRO do badania układu CommonRail [17]: 1 – urządzenie EDIA-PRO, 2 – kabel USB, 3 – komputer, 4 – kabel pomiarowy, 5 – sonda pomiarowa, 6 – wtryskiwacz, 7 – przewody wtryskiwacza, 8 – czujnik wysokiego ciśnienia, 9 – kabel podłączeniowy czujnika, 10 – złącze czujnika w samochodzie, 11 – kabel do pomiarów napięcia i ciśnienia sprężania, 12 – kabel do pomiaru sterowania zaworami regulacyjnymi

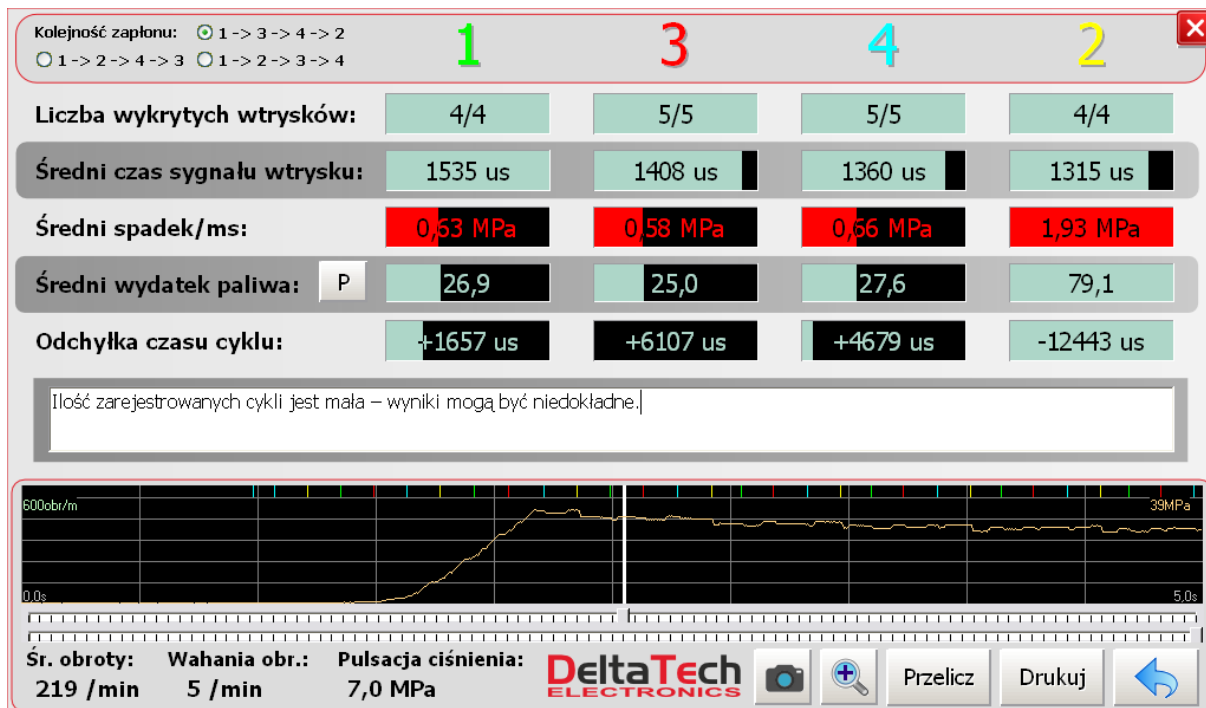

Fig. 15. Table of parameters - automatic analysis - diagnostic inference - obstructed injectors after improper regeneration, only injector No. 2 works properly [17]

Rys. 15. Tabela parametrów – analiza automatyczna – wnioskowanie diagnostyczne – niedrożne wtryskiwacze po niefachowej regeneracji, jedynie wtryskiwacz nr 2 funkcjonuje prawidłowo [17]



Fig. 16. Test bench for injectors with the EPS-200 tool from Bosch [10]

Rys. 16. Stanowisko do badania wtryskiwaczy z przyrządem EPS-200 firmy Bosch [10]

## 5. Conclusions

Laboratory tests, theoretical and practical analysis and experience from many years of workshop practice allow formulating the following conclusions:

- Damage to the injection equipment components of Common Rail systems may result from normal, long-term operation in harsh conditions and may be the result of improper operation of engines, i.e. supplying them with poor quality fuels that do not meet the standardized requirements in terms of properties, especially the content of impurities, chemical composition, lubricating properties. The conditions under which the agricultural vehicle is operated (paved road, field driving, unpaved road (dust, sand)), and atmospheric conditions result in fuel contamination.
- The most susceptible to premature wear components of the CR system are precision pairs: pistons and cylinders in high-pressure pumps, as well as needles and nozzle bodies. The most common wear is abrasive wear caused by poor

quality of fuel used and heat loads caused by high temperature and pulsating pressure in the order of 200 MPa. Cavitation erosion also occurs quite often in injection systems, which depends on the design and flow characteristics of the system and the properties of diesel fuel. Non-separated water contained in fuel causes corrosion of metal components, which in turn causes malfunction of the injection system, including the seizure of precision pairs. Corroded elements of the injector make it difficult to deliver fuel correctly. The following rules should be strictly observed: periodically replace fuel filters and buy fuel of the highest quality PREMIUM grade 1 or a good quality grade 2.

- There is also the use of fuel oil [6] containing benzene, xylene (which dissolve gaskets) and toluene (smoking), which significantly impair its lubricating properties, moreover, they react with the smallest amounts of sulphur to form hard dusts that damage the seals of high-pressure pumps, which translates into lower power, higher fuel consumption and visible leaks from the pump. In addition,

heating oil usually contains more than 0.5% sulphur, which is an unacceptable amount for CR as opposed to ordinary diesel fuel (less than 10 S2 particles per million, fuel particles - 0.01%). In many cases, the innovations introduced to tractors are a serious problem for the user, both in terms of the complexity and innovation of the systems used, as well as the level of competence of workshop employees [9].

## 6. References

- [1] Bocheński C.: Wpływ ciśnienia wtrysku i lepkości oleju napędowego na proces rozpylenia paliwa w silnikach ZS. MOTROL, 2004, 6, 5-7.
- [2] Bocheński C.: Biopaliwa w rolnictwie. Inżynieria Rolnicza, 2008, 1(99).
- [3] Günther H.: Układy wtryskowe Common Rail w praktyce warsztatowej. Wydawnictwo Komunikacji i Łączności, Warszawa 2011.
- [4] Huhtala K., Vilenius M.: Study of a common rail fuel injection system. SAE Technical Paper 2001-01-3184.
- [5] Idzior M., Borowczyk T., Karpiuk W., Stobnicki P.: Możliwości badania stanu technicznego nowoczesnych wtryskiwaczy silników o zapłonie samoczynnym. Logistyka, 2011, 3.
- [6] Jósko M., Kołodziejczyk D.: Przegląd techniki rolniczej i leśnej. Wybrane problemy eksploatacyjne pojazdów i maszyn rolniczych w zakresie ich serwisowania. 2008, 2.
- [7] Konieczny Ł., Adamczyk B., Adamczyk G.: Diagnostyka i regeneracja wtryskiwaczy CR. Zeszyty Naukowe Politechniki Śląskiej. Transport, 2015, 86.
- [8] Kruczyński S W., Chrupek B.: Niedomagania aparatury paliwowej Common Rail współczesnych silników o zapłonie samoczynnym Zeszyty Naukowe Instytutu Pojazdów Politechniki Warszawskiej, 2014, 4, 100.
- [9] Osipowicz T., Abramek K. F.: Catalytic treatment in Diesel engine injectors. Eksploatacja i Niezawodność – Maintenance and Reliability, 2014, Vol. 16, 1.
- [10] Stoeck T., Abramek K. F.: Application of the polynomial interpolation method for determining performance characteristics of a diesel engine. Metrol. Meas. Syst., 2014, Vol. XXI, 1, 157-168.
- [11] <http://www.delphi.com/manufacturers/cv/powertrain/common-rail-systems/f2distributed-pump-diesel>.
- [12] Rozporządzenie Parlamentu Europejskiego i Rady Nr 715/2007 z dnia 20 czerwca 2007 r., w sprawie homologacji typu pojazdów silnikowych w odniesieniu do emisji zanieczyszczeń z lekkich pojazdów pasażerskich i użytkowych (Euro 5 i Euro 6).
- [13] Materiały techniczne i informacyjne producenta NCH; instrukcje serwisowe.
- [14] Materiały techniczne i informacyjne Techbud Zielona Góra Sp. z o.o.
- [15] Materiały informacyjne Bosch - Service.
- [16] Materiały informacyjne firmy Turbo-Tec Sp. z o.o.
- [17] Nowoczesny Warsztat. Wydawnictwo Tczew, 2017, 4(212).